

**Sears**

**owners  
manual**

**MODEL NO.  
247.298760**

**CAUTION:**  
Read **SAFETY  
RULES** and  
**INSTRUCTIONS**  
carefully

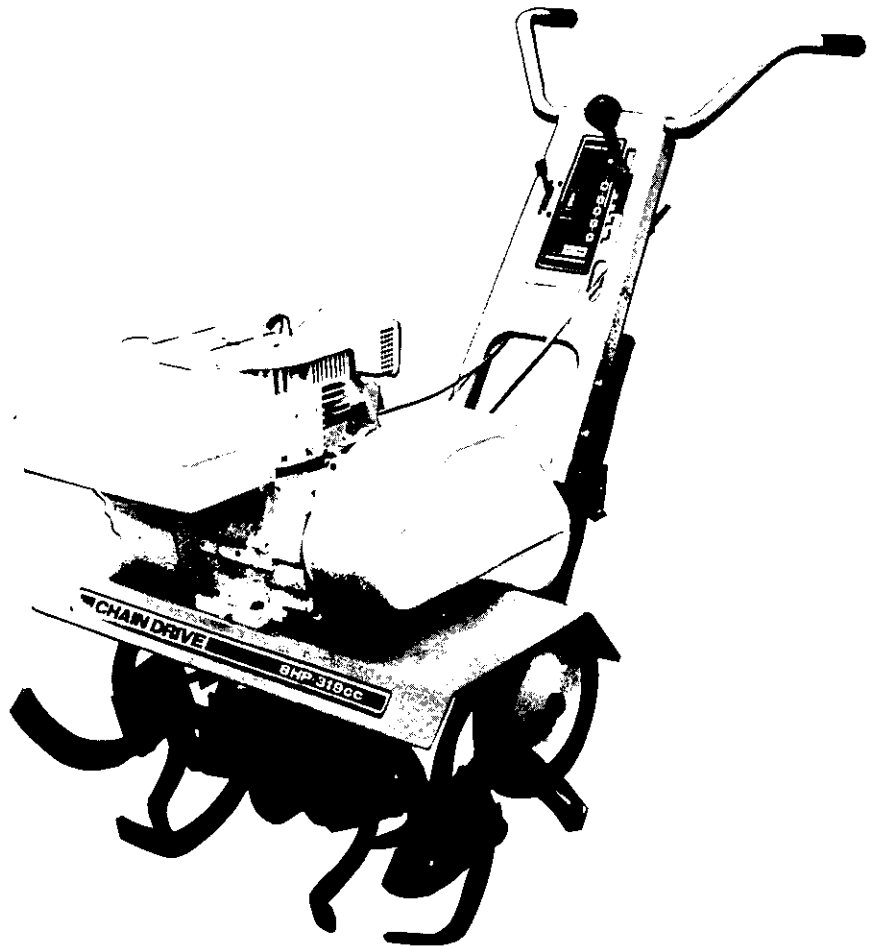

**Sears**

**CRAFTSMAN®**

**8 H.P. FOUR SPEED  
CHAIN DRIVE TILLER**

- **Assembly**
- **Operating**
- **Maintenance**
- **Repair Parts**

**SEARS, ROEBUCK AND CO., Chicago, ILL. 60684 U.S.A.**

## **FULL ONE YEAR WARRANTY**

For one year from the date of purchase, Sears will repair any defect in material or workmanship in this TILLER at no charge.

If the TILLER is used for commercial or rental purposes, this warranty applies for only thirty days from the date of purchase.

Warranty service is available by contacting the nearest Sears store or Service Center throughout the United States.

This warranty gives you specific legal rights, and you may also have other rights which vary from state to state.

Sears, Roebuck and Co.  
Sears Tower  
BSC 41-3  
Chicago, IL 60684

# **IMPORTANT**

It is suggested that this manual be read in its entirety before attempting to assemble or operate. Keep this manual in a safe place for future reference and for ordering replacement parts.

This unit is shipped **WITHOUT GASOLINE** or **OIL**. After assembly, see operating section of this manual for proper fuel and amount.

Your tiller is a precision piece of power equipment, not a play thing. Therefore exercise extreme caution at all times.

## **SAFE OPERATION PRACTICES FOR TILLERS**

1. Read the Operating and Service Owner's Manual carefully. Be thoroughly familiar with the controls and the proper use of the equipment.
2. Never allow children to operate a power tiller. Only persons well acquainted with these rules of safe operation should be allowed to use your tiller.
3. Keep the area of operation clear of all persons, particularly small children and pets.
4. Do not operate equipment when barefoot or wearing open sandals. Always wear substantial footwear.
5. Do not wear loose fitting clothing that could get caught on the tiller.
6. Do not start the engine unless the shift lever is in the neutral (N) position.
7. Do not stand in front of the tiller while starting the engine.
8. Do not place feet and hands on or near the tines when starting the engine or while the engine is running.
9. Do not leave the tiller unattended with the engine running.
10. Do not walk in front of the tiller while the engine is running.
11. Do not fill gasoline tank while engine is running. Spilling gasoline on hot engine may cause a fire or explosion.
12. Do not run the engine while indoors. Exhaust gases are deadly poisonous.
13. Be careful not to touch the muffler after the engine has been running, it is hot.
14. Before any maintenance work is performed or adjustments are made, remove the spark plug wire and ground it on the engine block for added safety.
15. Use caution when tilling near buildings and fences, rotating tines can cause damage or injury.
16. Before attempting to remove rocks, bricks and other objects from tines, stop the engine and be sure the tines have stopped completely. Disconnect the spark plug wire and ground to prevent accidental starting.
17. Check the tine and engine mounting bolts at frequent intervals for proper tightness.
18. Keep all nuts, bolts and screws tight to be sure the equipment is in safe working condition.
19. Never store the equipment with gasoline in the tank inside of a building where fumes may reach an open flame or spark. Allow the engine to cool before storing in any enclosure.

### **NOTE**

A spark arrest muffler is available as an accessory part. The part number is listed in the parts section of this manual. Check muffler legal requirements in your area

# INDEX

Warranty .....	2	Maintenance .....	14
Rules for Safe Operation .....	3	Belt Replacement .....	14
Introduction .....	4	Care and Maintenance—Transmission .....	15
Hardware Pack .....	5	Care and Maintenance—Engine .....	15
Tiller Identification .....	6	Carburetor Adjustment .....	16
Assembly Instructions .....	7	Storage .....	17
Engine Preparation .....	10	Repair Parts—Tiller .....	18
Operation .....	11	List of Tiller Accessories .....	21
Controls .....	12	Repair Parts—Transmission .....	22
Tilling .....	12	Repair Parts—Engine .....	23
Cultivating .....	13	How To Order Repair Parts .....	Back Cover

## INTRODUCTION

This Product has been designed, engineered and manufactured to give you the best possible dependability and performance.

Should you experience any problem you cannot easily remedy, please contact your nearest Sears, or Simpson-Sears Service Department. They have well qualified, competent trained technicians and the proper tools to service or repair this unit.

### PRE-ASSEMBLY



The right and left side of your tiller is determined from operator's position.

Before any step is undertaken, the instructions for that step should be read through.

#### TOOLS REQUIRED: See Figure 1

1. (1) 1/2" Socket, open or box wrench.
2. (2) 9/16" Socket, open or box wrench.
3. (1) 1/4" Flat Screwdriver.

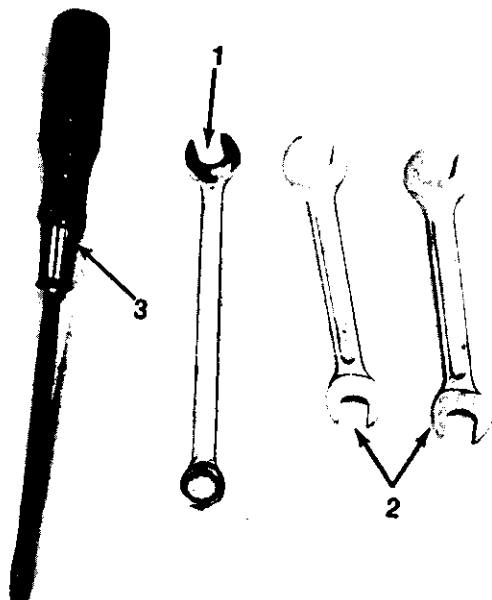

FIGURE 1.

#### MATERIALS REQUIRED:

1. Funnel (for gas and oil - **NOTE: DO NOT MIX**)
2. S.A.E.-30 Oil-For Service SC, SE, SD or MS  
1 1/2 pints
3. Gas (regular)
4. Cleaning rag

#### PARTS IN CARTON (See figure 2.)

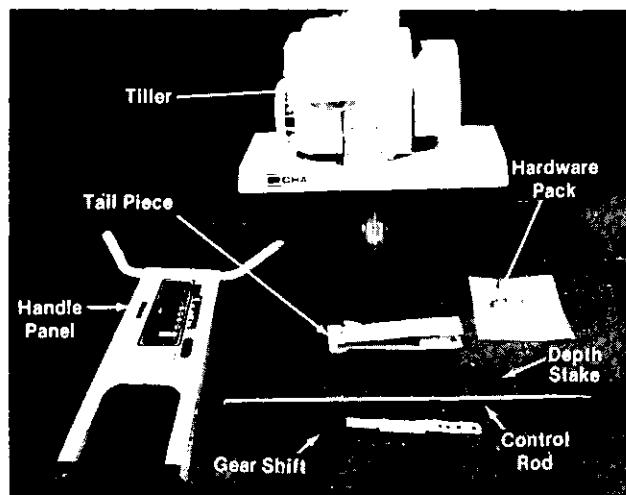

FIGURE 2.

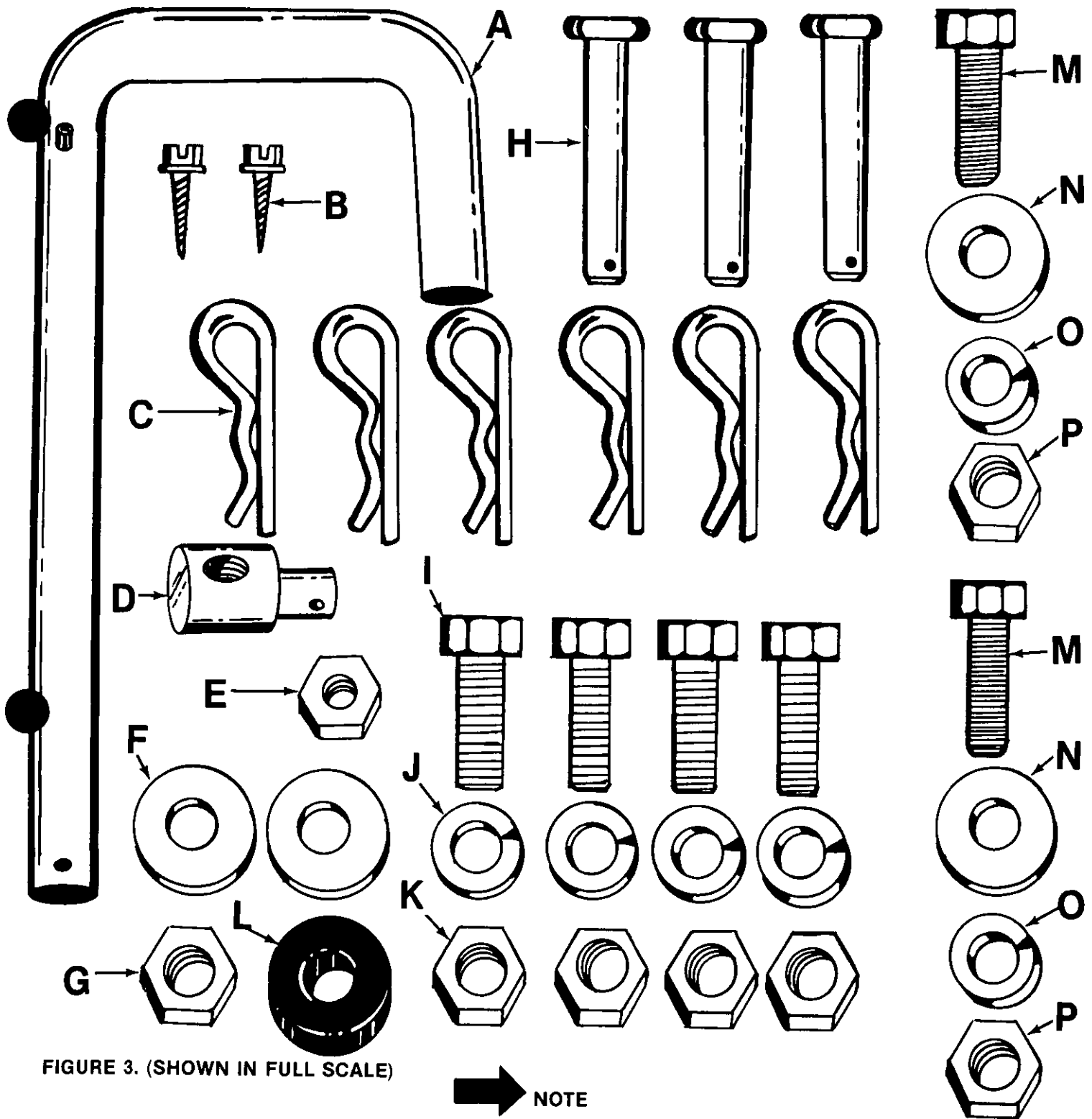

FIGURE 3. (SHOWN IN FULL SCALE)

**NOTE**

The letters listed below will be referred to throughout the following text for easier hardware identification.

**LIST OF CONTENTS IN HARDWARE PACK:**

- A (1) "U"-Clevis Pin 1/2" Dia.
- B (2) Self Tapping Screws #8 x .62"
- C (6) Hair Pin Cotter
- D (1) Ferrule
- E (1) Hex Center Locknut 5/16-18 Thread
- F (2) Flat Washers
- G (1) Hex Center Locknut 5/16-18 Thread
- H (3) Clevis Pins

- I (4) Hex Screws 3/8-16 x 1.00"
- J (4) Lockwashers 3/8"
- K (4) Hex Nuts 3/8-16 Thread
- L (1) Rubber Washer
- M (2) Hex Screws 3/8-24 x 1.00"
- N (2) Belleville Washer
- O (2) Lockwashers 3/8"
- P (2) Hex Nuts 3/8-24 Thread

# TILLER IDENTIFICATION

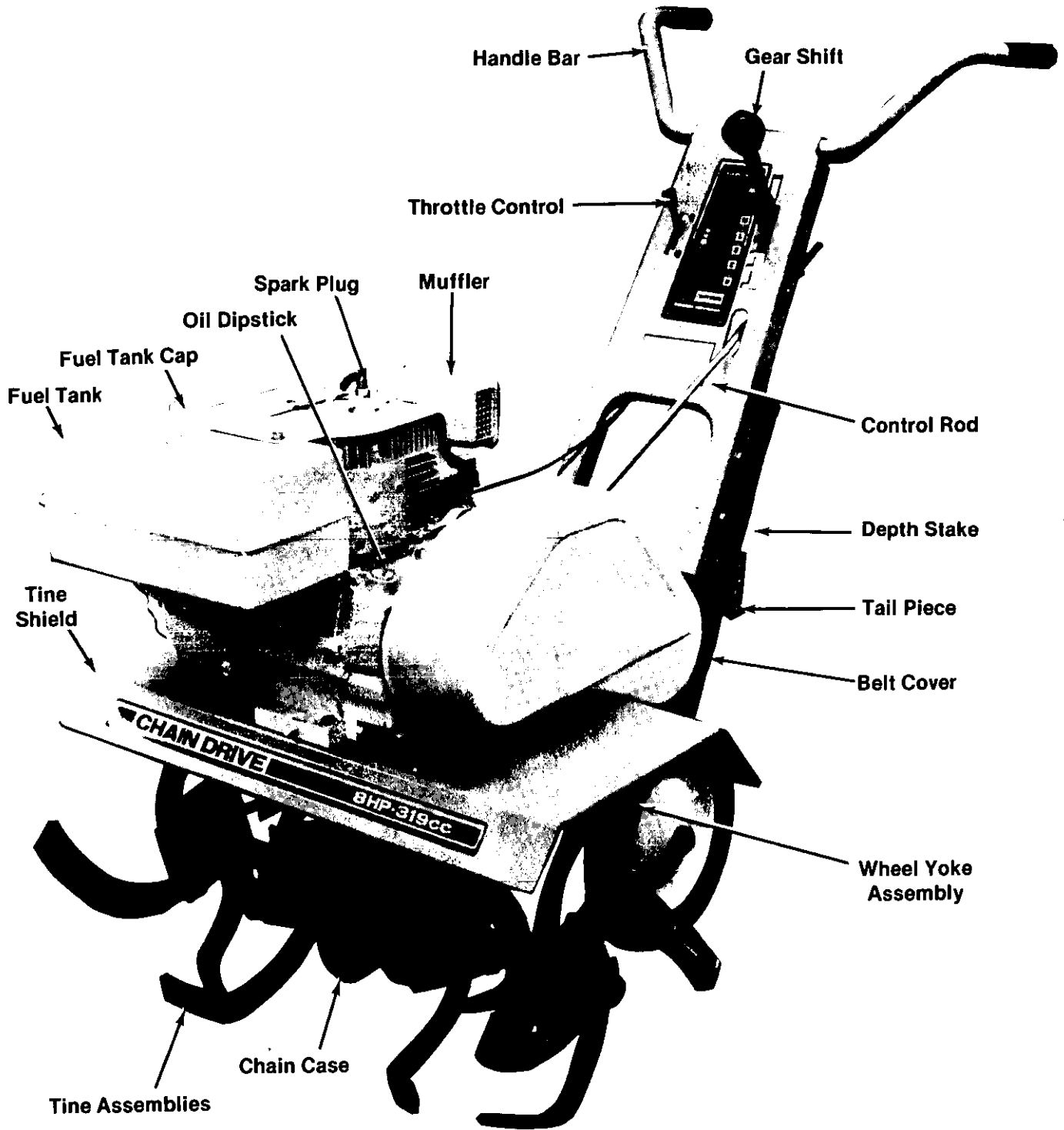

FIGURE 4.

# ASSEMBLY INSTRUCTIONS

## 1. Handle Panel Attachment.

For shipping purposes, the handle mounting brackets are pivoted down. With a 9/16" wrench loosen the hex bolt holding the handle mount brackets. See figure 5.

Pull handle mount brackets up so that the top hole in bracket lines up with forward hole in chassis. See figure 5.

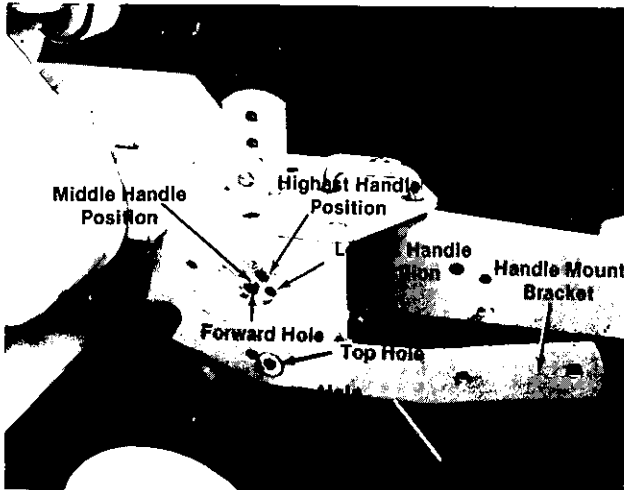

FIGURE 5.

Secure handle mount brackets with hex bolt (M), belleville washer (N), lockwasher (O) and hex nut (P). See figure 6.

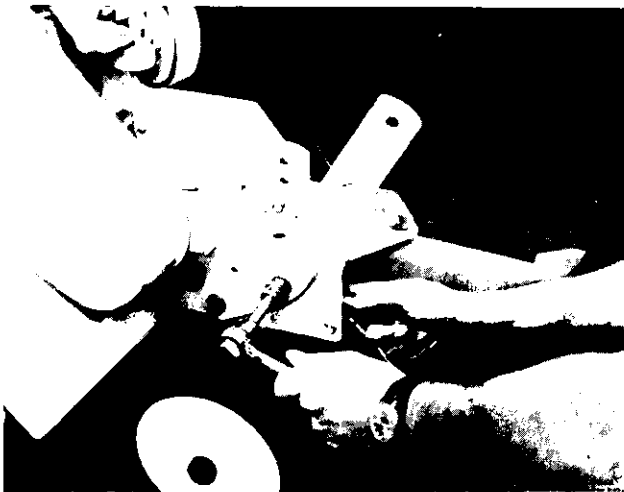

FIGURE 6.

The handle panel is attached by sliding it down over the handle brackets on the chassis and installing four hex bolts in the lower holes of the handle panel. Place bolts through the handle panel; head to the outside. See figure 7.



Do not tighten until all four bolts are in place.

Four hex bolts (I), lockwashers (J) and hex nuts (K) will be found in the hardware pack. See figure 7.

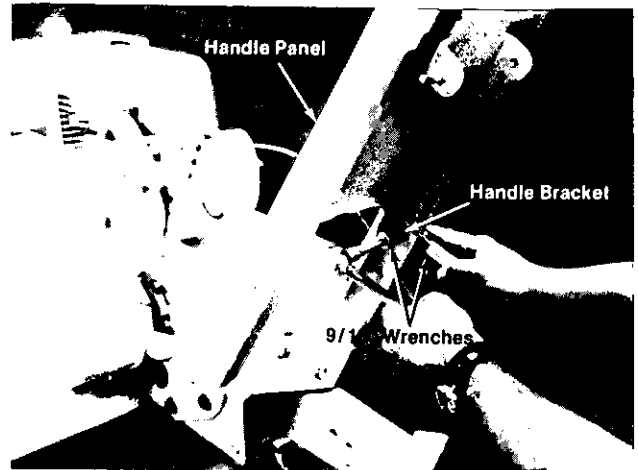

FIGURE 7.

## 2. Throttle Control Lever.

Place throttle control lever up through the handle panel and secure with two self tapping screws (B), using a 1/4" flat screwdriver. See figure 8.



FIGURE 8.

## 3. Gear Shift Lever.

The shift lever is mounted to the handle panel in the following steps.

- A. Place the top hole of the shift lever over weld bolt on handle panel. See figure 9.
- B. Place one flat washer (F), rubber washer (L) and the other flat washer (F) over weld bolt on handle panel. See figure 9.

C. Secure with hex center locknut (G). See figure 9.

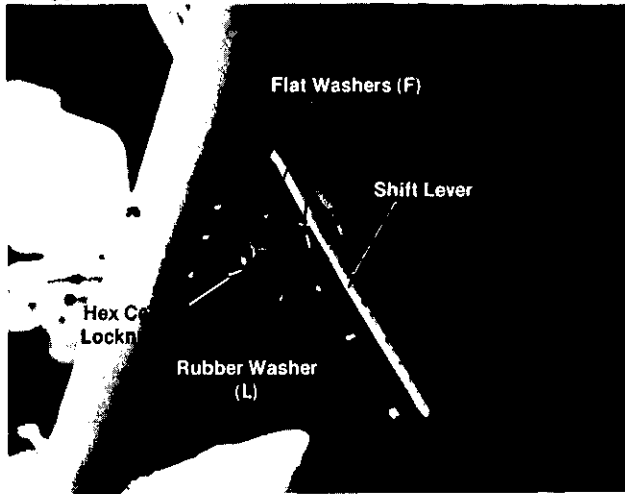

FIGURE 9.



**NOTE**

Tighten hex locknut just to the point the rubber washer starts to compress.

**4. Control Rod.**

A. Place control rod through slot in handle panel, hook end of rod goes towards the front of tiller. See figure 10.

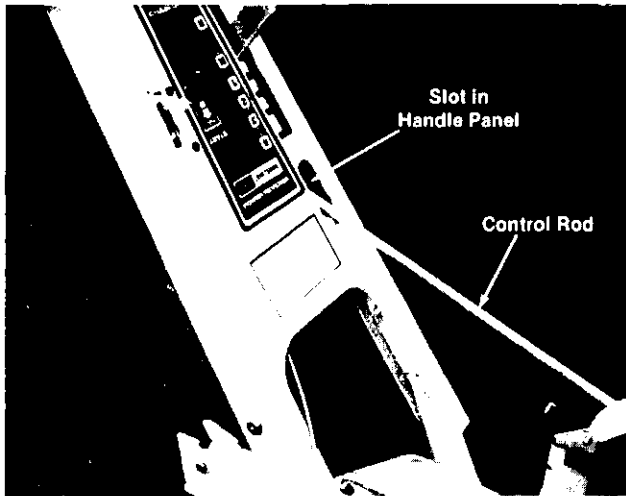

FIGURE 10.

B. Hook control rod in hole provided on pivot arm assembly as shown in figure 11. Secure control rod to pivot arm assembly with hair pin cotter (C). See figure 11.

C. Please note there are three holes left on the shift lever. Use the second hole from bottom for the next step. See figure 12.

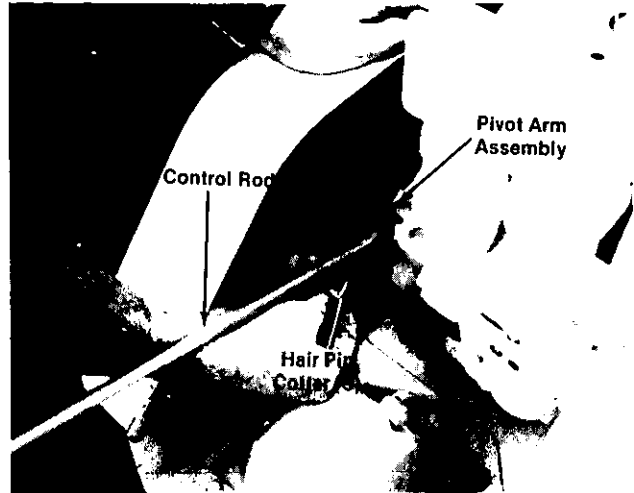

FIGURE 11.

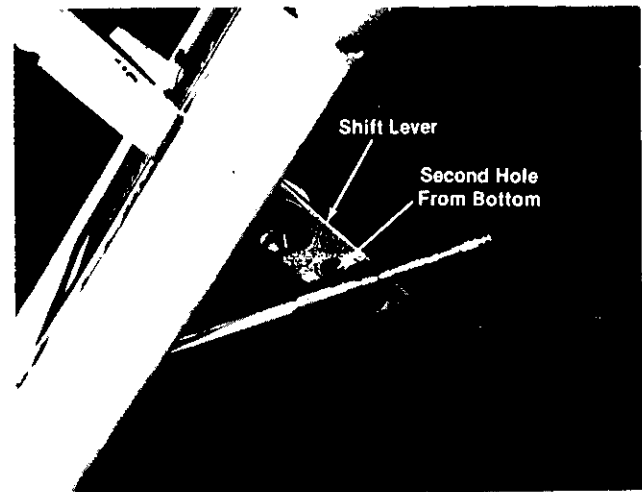

FIGURE 12.

D. Place shift lever in first gear and thread ferrule (D) on end of control rod until ferrule lines up with second hole on shift lever. See figure 13. Secure with hair pin cotter (C). See figure 13.

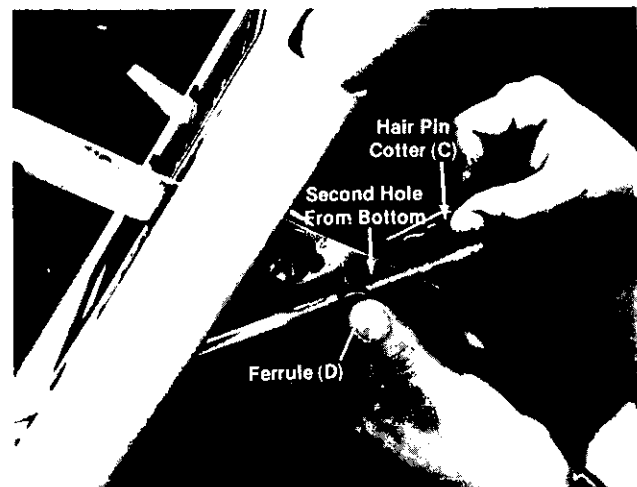

FIGURE 13.





## NOTE

Shift lever and control rod must be readjusted whenever you change the handle height.

### 5. Tine Attachment

- a. The outer tines have been reversed on the tine shaft for shipping purposes. See figure 14.

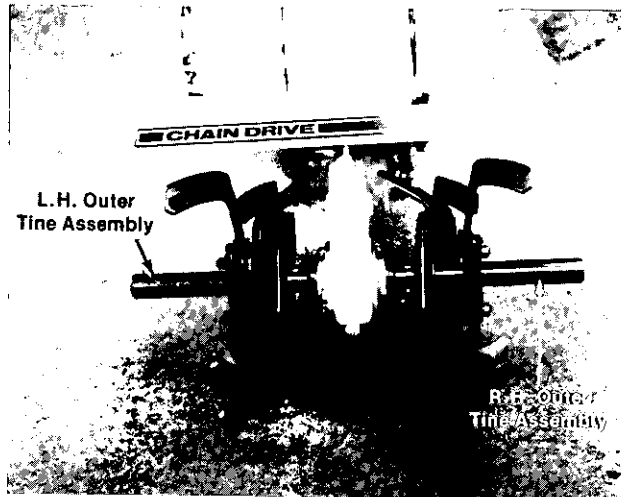

FIGURE 14.

Remove outer tines from the tine shaft and reinstall with the tine hub facing inward as illustrated in figure 15. Secure tines with clevis pins (H) and hair pin cotters (C).

- b. The inner tine assemblies have been installed at the factory and in their correct operating position and do not require changing.
- c. See tine adjustment for information on changing width of tilling path, page 13.

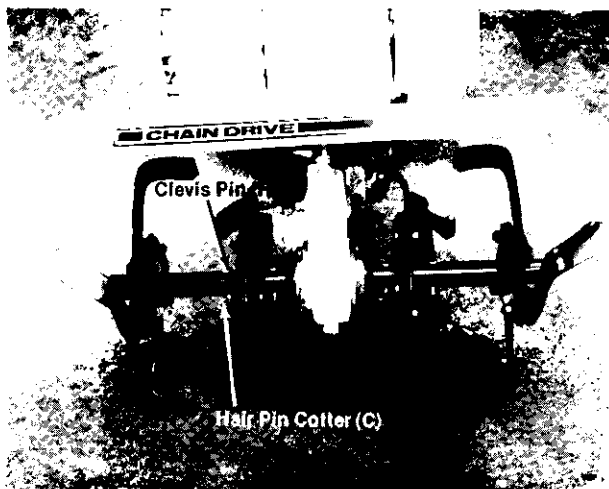

FIGURE 15.

### 6. Tail Piece Attachment.

Slide the tail piece into the chassis and secure with "U" clevis pin (A) and hair pin cotter (C). See figure 16.

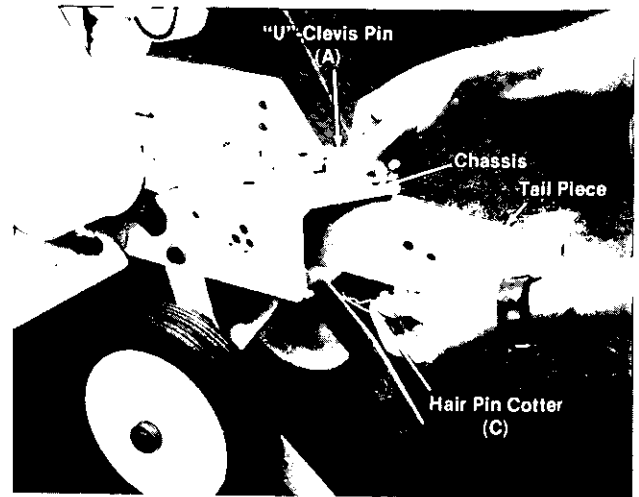

FIGURE 16.

### 7. Depth Stake Attachment.

Slide the depth stake into the tail piece (round end up) and secure with clevis pin (H) and hair pin cotter (C). See figure 17.

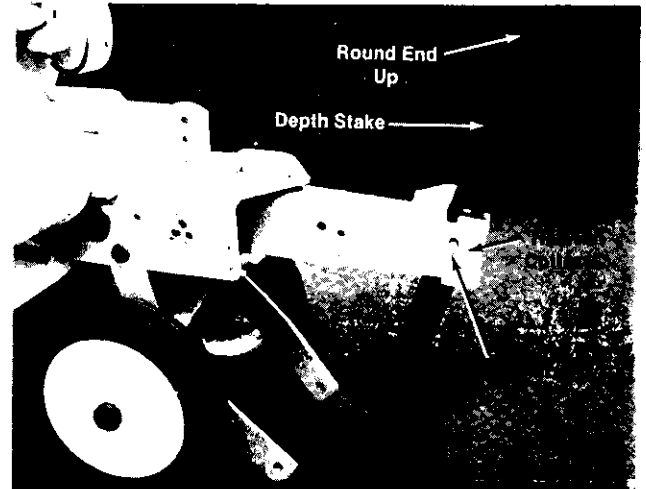

FIGURE 17.

## ENGINE PREPARATION



FIGURE 18.

## OIL AND FUEL RECOMMENDATIONS



### CAUTION

Oil must be added before starting.

To start and operate your Tecumseh engine, you will need the following:

1. Fill crankcase with a clean, high quality detergent oil.

Be sure original container is marked with engine service classification "SC," "SD," or "SE."

**For Summer (Above 32°F). Use SAE 30 oil.** (SAE 10W-30 or 10W-40 are acceptable substitutes.)

**For Winter (Below 32°F). Use SAE 5W-30 oil.** (SAE 10W is an acceptable substitute.)

**(Below 0°F Only)** SAE 10W oil diluted with 10% Kerosene is acceptable.

Crankcase capacity is approximately 24 ounces (1½ pints). See figure 19. Fill to full mark on oil dipstick.

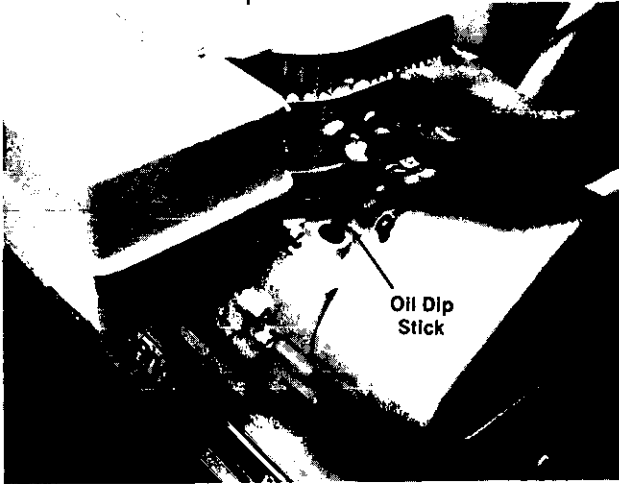

FIGURE 19.



FIGURE 20.

2. A fresh, clean, unleaded automotive gasoline. (Leaded "Regular" grade gasoline is an acceptable substitute.) See figure 20.

**NEVER FILL FUEL TANK COMPLETELY. FILL TANK TO WITHIN ¼ TO ½ INCH OF TOP OF TANK TO PROVIDE SPACE FOR FUEL EXPANSION. WIPE ANY FUEL SPILLAGE FROM ENGINE AND EQUIPMENT BEFORE STARTING ENGINE.**



### NOTE

Use clean oil and fuel and store in approved, clean covered containers. Use clean fill funnels.

## OPERATION

TO START ENGINE:

1. CAUTION: BE SURE NO ONE IS STANDING IN FRONT OF THE TILLER WHILE THE ENGINE IS RUNNING OR BEING STARTED.

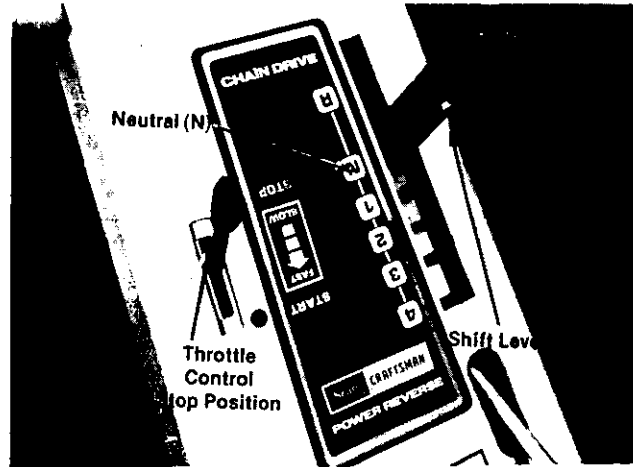

FIGURE 21.

2. Place the shift lever in the neutral (N) position. See figure 21.



FIGURE 22.

3. Choke Engine. Push choke lever to choke engine. See figures 22 and 23. Once the engine starts, pull back on choke lever.

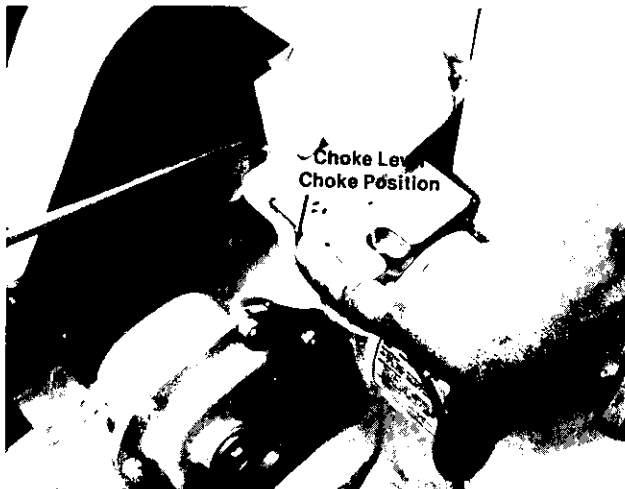

FIGURE 23.

4. Move the throttle control lever forward to FAST POSITION. See figure 24.

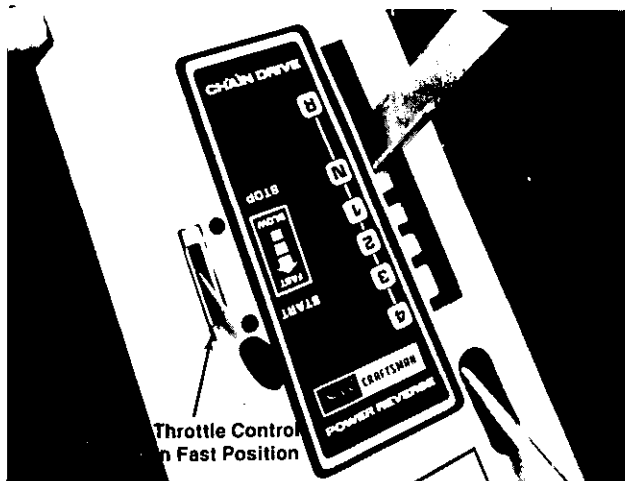

FIGURE 24.

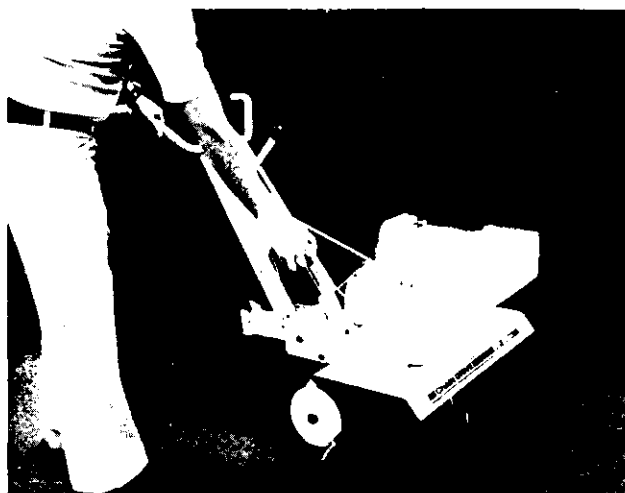

FIGURE 25.

5. Stand at side of the tiller, grasp the starter handle and pull out rapidly. Return it slowly to the engine. Repeat as necessary. See figure 25.



If engine is warm, start with the control in the "FAST" position. Choking may not be necessary. See figure 24.

6. Move the throttle control to SLOW when transporting the tiller. When the tiller is being moved to or from the garden, the depth bar should be pivoted forward until it engages the depth bar retainer clip. The machine may be moved under its own power, without seriously damaging grass areas as long as it is allowed to move freely. If the operator holds back, it will start to dig.

## CONTROLS

### LOCATION AND USE.

1. Shift Lever: The shift lever is located on the left hand side of the handle panel. Left hand is determined from the operator's position, standing behind the tiller.
  - A. Forward (F)—Move the lever to the right and down (Forward) to set unit in motion. See figure 26.
  - B. Neutral (N)—Move lever to center detent. See figure 24.
  - C. Reverse (R)—Pull the lever back (upward) slowly and intermittently. See figure 27.

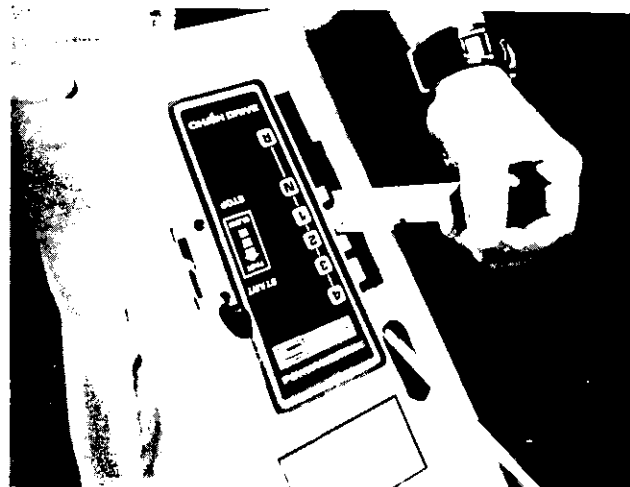

FIGURE 26.

2. **Throttle Control:** The throttle control lever is located on the right hand side of handle panel.
  - A. **Stop**—Pull lever back (upward) to stop the unit. See figure 21.
  - B. **Start**—Push lever forward (down) to start unit. See figure 22.

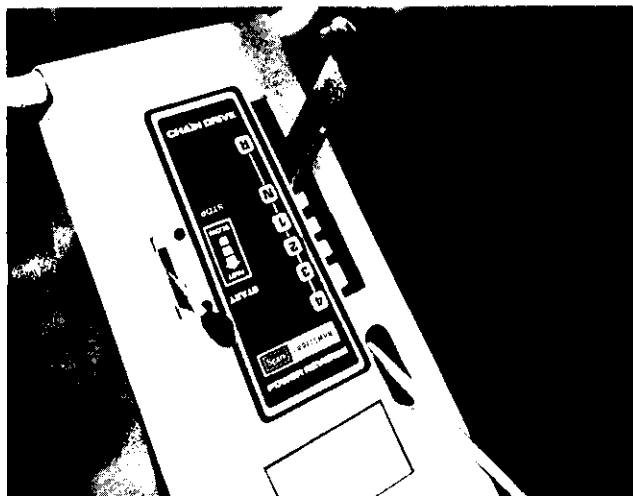

FIGURE 27.

## TILLING

1. Adjust depth bar by removing clevis pin and hair pin cotter, changing bar position, then replacing hair pin cotter and clevis pin. See figure 17.
  - A. Lowering the depth bar will slow the tiller and make it till deeper.
  - B. Raising the depth bar will allow the tiller to move faster and till shallower.
  - C. For normal tilling, set depth bar at the fifth or sixth hole from the top.
2. Adjust wheel yoke by removing clevis pin and hair pin cotter, changing wheel yoke height, and replacing clevis pin. See figure 17.
  - A. Raising the wheel yoke will allow the tiller to till deeper.
  - B. Lowering the wheel yoke will allow the tiller to till shallower.
  - C. For normal tilling set wheel height at the second or third hole from the top.

## TILLING HINTS

Soil conditions are important for proper tilling.

The tines will not readily penetrate dry, hard soil. This may contribute to excessive bounce and difficult handling of the tiller. Hard soil should be moistened prior to tilling.

Extremely wet soil will cause soil to ball up or clump.

When tilling in the Fall, all vines and long grass should be removed. This will prevent vines from wrapping around the tine shaft which slows tilling operation.

1. The best method will be determined by the soil condition. In some soils, the desired depth is obtained the first time over the garden. In other soils, the desired depth is obtained by going over the garden two or three times. In the latter case, the depth stake should be lowered before each succeeding pass over the garden, and passes should be made across the length and width of the garden alternately. Rocks which are turned up should be removed from the garden area.

2. **Handle Pressure:** Further control of tilling depth and travel speed can be obtained by variation of pressure on the handles.

When using the depth bar a downward pressure on the handles will increase the working depth and reduce the forward speed. An upward pressure on the handles will reduce the working depth and increase the forward speed. The type of soil and working conditions will determine the actual setting of the depth bar and the handle ground, while the tiller is resting on the tines.

## CULTIVATING

For cultivating, a two to three inch depth is desirable. Setting the wheels and depth bar so that the wheels are about two inches above the ground, while the tiller is resting on the tines and depth bar, will allow the machine to work at cultivating depth. The throttle should be set to control forward movement to a slow walking speed. With standard tines, the working width of the machine is 26 inches. See figure 28.



FIGURE 28.

Tilling width can be increased from 26 inches to 28 inches by removing the clevis pin and hair pin cotter and sliding the outer tines out one (1) inch, and replacing the clevis pin and hair pin cotter. See figure 29.

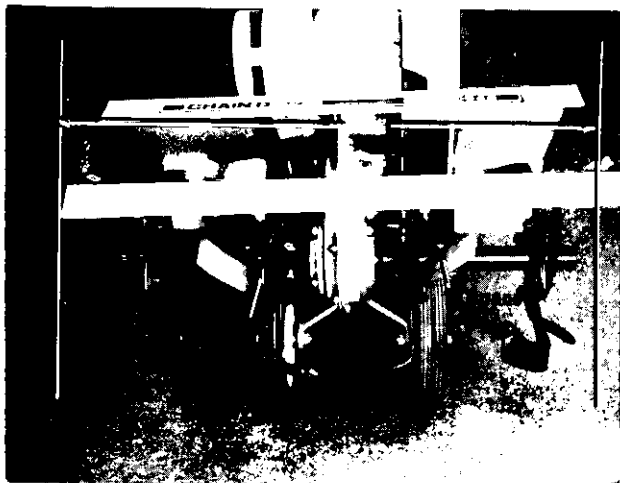

**FIGURE 29.**

For cultivation, this may be reduced to 14 inches by removing the outer tines. See figure 30.



**FIGURE 30.**

In laying out plant rows be sure to allow enough width (14" to 15") to permit cultivation between the rows.

In growing corn or similar crops, check-row planting will permit cross cultivation and practically eliminate hand hoeing. The tiller has many uses other than tilling and cultivating a garden. One of these is the preparation of lawn area for seeding. The tiller will prepare a deep seed bed which will be free of hard untilled spots, allowing a better stand of grass to grow. The tiller is very useful for loosening hard soil for excavation with a shovel. Your tiller may be used for mixing compost in the pile, or for mixing it with the soil in your garden. This should be done after the soil has been broken to the full working depth.

The compost should be worked in to a depth of six to eight inches. This may be done by working the length of the garden, and then by mixing separate passes across its width. The addition of decayed organic matter will substantially increase the fertility of your garden. For proper decaying action, fertilizer should be applied and worked in with the mulch materials. The breaking up of the leaves and straw and the mixing of it with the several inches of soil cause the soil to hold moisture longer and allow proper aeration of the plant root system. This also retards the growth of weeds.

The U.S. Department of Agriculture and various state and local agencies offer published booklets and expert advice on all phases of gardening. They should be consulted regarding soil information, planting dates, and the most satisfactory varieties of crop for your particular area.

## MAINTENANCE

### BELT REPLACEMENT:

If belt replacement is required order belt or belts by part number from your nearest Sears Service Center.

- FORWARD DRIVE BELT - Part No. 754-0232  
1/2" x 20" long
- REVERSE DRIVE BELT - Part No. 754-0231  
1/2" x 28" long

Your tiller has been engineered with the above belts and should not be replaced with an off-the-shelf belt. The above belts are of special material (Kevlar Tensile).

### Removing and replacing the REVERSE DRIVE BELT.

1. Remove the belt cover, by removing two (2) self tapping screws, and one (1) hex nut. See figure 31.

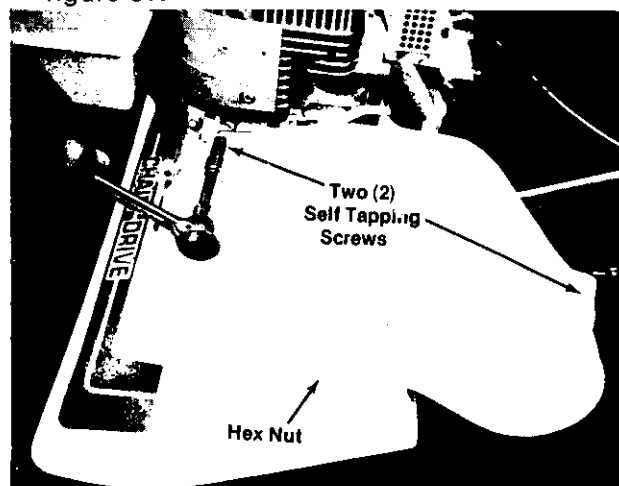

**FIGURE 31.**

2. Push forward on the idler and lift belt off of chain case pulley, idler pulley and variable speed pulley. See figure 32.

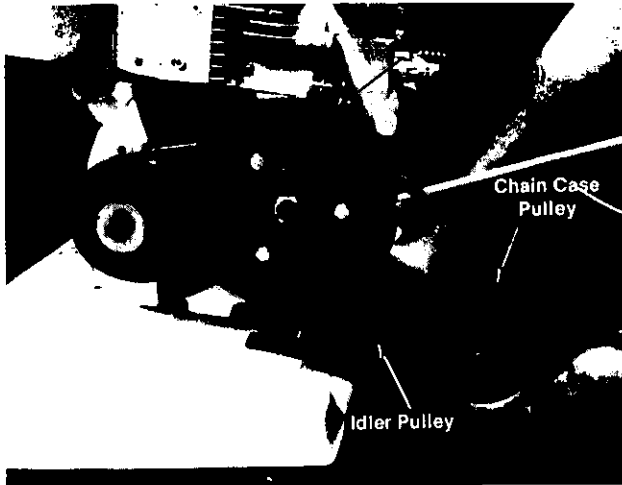

**FIGURE 32.**  
Removing and replacing the FORWARD DRIVE BELT.

1. To remove the forward drive belt you must remove the reverse drive belt first. See removing the reverse drive belt section, steps 1 and 2.
2. Push the shift lever forward and lift off belt from variable speed pulley and engine pulley. See figure 33.

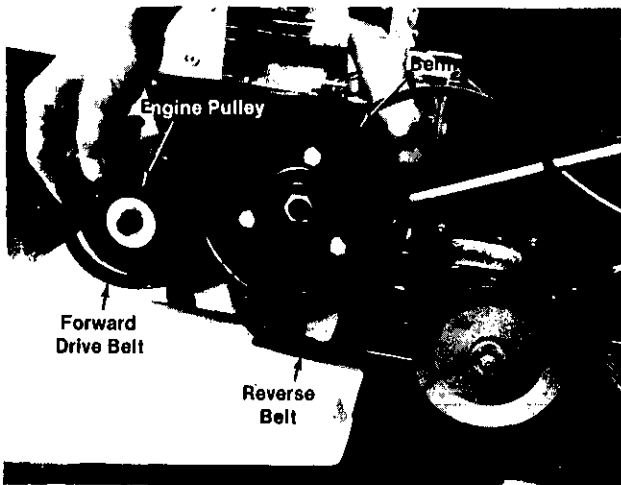

**FIGURE 33.**  
**CARE AND MAINTENANCE:**

**Transmission:**

The transmission is pre-lubricated and sealed at the factory. It requires no additional lubrication unless the transmission is disassembled. To fill with grease, lay the left half of the chain case on its side, add 14 ounces of Plastilube #1 grease and assemble the right half to it. This grease can be from your nearest Sears Service Center. (Order Part No. 737-0133.)

**Engine:**

1. You **MUST CHANGE THE OIL** in the crankcase after the first two hours of operation of your new engine and after each 25 hours of use thereafter to ensure proper lubrication of internal parts for trouble free operation and to prevent costly repair due to excessive wear. (Take care to remove dirt around dip stick.) Be sure oil level is maintained full to mark. See figure 19.

To change oil remove drain plug (figure 34) and tip the tiller forward while engine is warm. Replace drain plug. Remove oil dip stick and refill with new oil of proper grade. Replace dip stick.

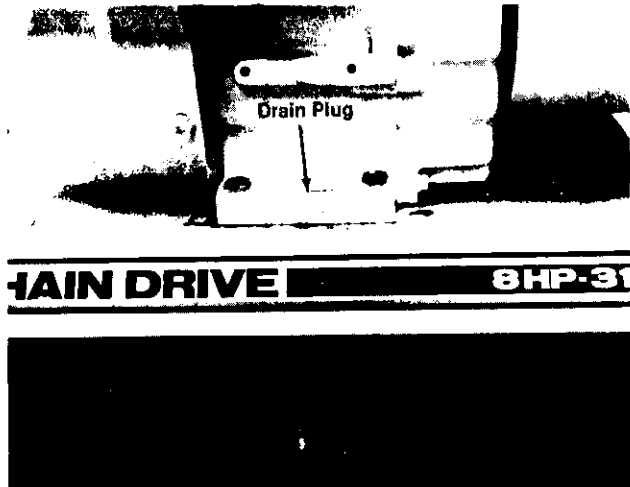

**FIGURE 34.**

2. Always use the **PROPER FUEL** in your engine. Use only a good grade of fresh, clean, regular gasoline. Do not use gasoline that has been sitting for a long period of time. Stale gasoline may cause engine to run poorly or not at all.
3. Keep your engine **CLEAN**. Wipe off all spilled fuel and oil. Keep the engine clean of foreign matter and be sure the cooling fins on the cylinder are kept clean to permit proper air circulation. You must **REMEMBER** that this is an air cooled engine and free flow of air is essential to proper engine performance and life.
4. You must **SERVICE YOUR AIR CLEANER**. Clean every 10 operating hours, or more often if used in extremely dusty or dirty areas. Proceed as follows:
  - A. Remove wing nut, cover and filter.
  - B. Tap top or bottom of filter lightly on a flat surface to dislodge any dirt (low pressure air blown carefully from inside of filter may also be used)—or wash filter in water

and detergent solution and flush from inside until water is clear. Be sure filter is completely dry before reassembling to engine. **DO NOT OIL FILTER. IF IT IS PUNCTURED, TORN OR UNCLEANABLE, IT SHOULD BE REPLACED.** Replacement filters are available at your nearest Authorized Sears Service Center.

- C. Before replacing filter, clean inside of base and cover thoroughly.
- D. Replace filter and cover making sure filter is seated correctly between base and cover. Tighten wing nut securely. See figure 35.

**NEVER RUN ENGINE WITHOUT COMPLETE AIR CLEANER INSTALLED ON ENGINE.**

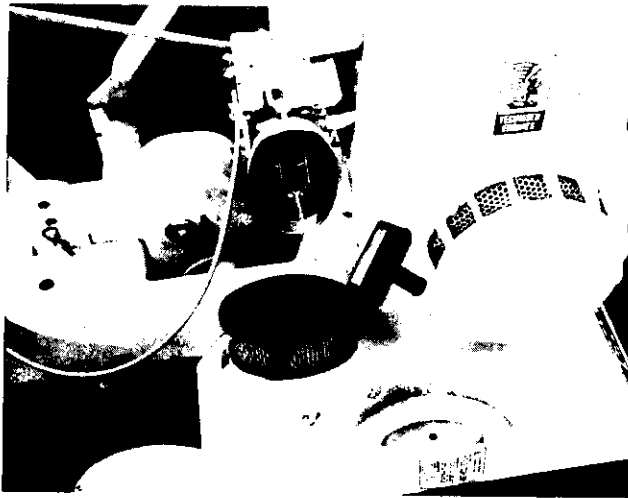

FIGURE 35.

## ADJUSTMENTS

DO NOT MAKE UNNECESSARY ADJUSTMENTS. FACTORY SETTINGS ARE SATISFACTORY FOR MOST APPLICATIONS AND CONDITIONS. IF ADJUSTMENTS ARE NEEDED, PROCEED AS FOLLOWS:

### 1. Carburetor Adjustments (See figure 36.)

- A. High speed adjust needle is pre-set at the factory. (1½ turns open)  
Re-adjustment should not be necessary.
- B. Close idle adjust needle by turning clockwise. Close finger tight only. Forcing may cause damage.
- C. Open idle adjust needle by turning 1¼ turns counterclockwise.
- D. Start engine. Follow preceding starting instruction. Run engine a few minutes to warm it up.

- E. With engine running at idle speed, adjust idle adjust needle 1/8 turn at a time, clockwise and counterclockwise, until engine runs smoothly.

Allow several seconds between each adjustment for engine to adapt to new setting.

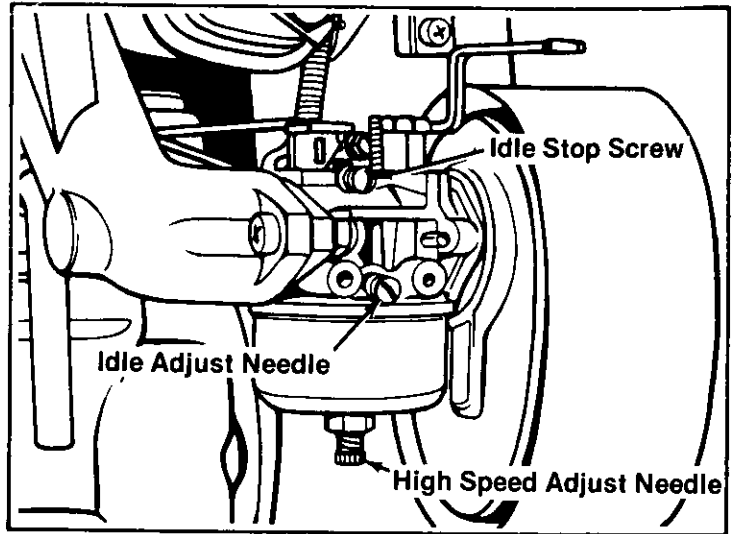

FIGURE 36.

### 2. Remote Control Adjustments (See figure 37.)

To obtain satisfactory engine performance, the engine and remote equipment controls must be adjusted properly. If it is necessary to check the engine control adjustments, proceed as follows:

- A. Set remote equipment control at FAST or HIGH SPEED and keep it in this position. With control in this position, control lever should touch high speed stop. If it does, the controls are adjusted correctly and no further adjustment should be necessary. If control lever does not touch high speed stop, proceed to Instruction B.
- B. Loosen clamp screw just enough so remote control cable can be moved in cable clamp (do not remove cable clamp from control bracket or disconnect. Remote control cable from control lever).
- C. Move control lever so it is touching high speed stop and hold it in this position. With control lever in this position, tighten clamp screw so that cable clamp will hold remote control cable in place when remote equipment control is used.  
The engine controls should now be adjusted correctly.

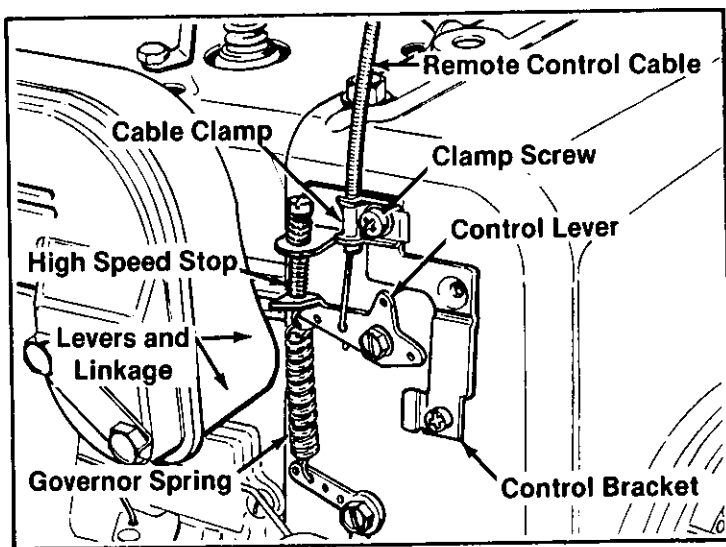

FIGURE 37.

3. **NEVER TAMPER WITH ENGINE GOVERNOR WHICH IS FACTORY SET FOR PROPER ENGINE SPEED. OVERSPEEDING ENGINE ABOVE FACTORY HIGH SPEED SETTING CAN BE DANGEROUS. IF YOU THINK THE ENGINE GOVERNED HIGH SPEED NEEDS ADJUSTING, CONTACT YOUR NEAREST AUTHORIZED SEARS SERVICE CENTER, WHO HAS THE PROPER EQUIPMENT AND EXPERIENCE TO MAKE ANY NECESSARY ADJUSTMENTS.**

**SPARK PLUG:**

1. Remove the spark plug each time you change the oil and inspect it. See figure 38.
  - A. The electrodes should be kept clean and free OF CARBON. The presence of carbon or excess oil will greatly deter proper engine performance.
  - B. If possible, check the spark plug gap (area between electrodes) using a wire feeler gauge. This specification should be .030.
2. If you need a spark plug refer to the yellow pages of your phone book under "Engines Gasoline" for an authorized dealer.

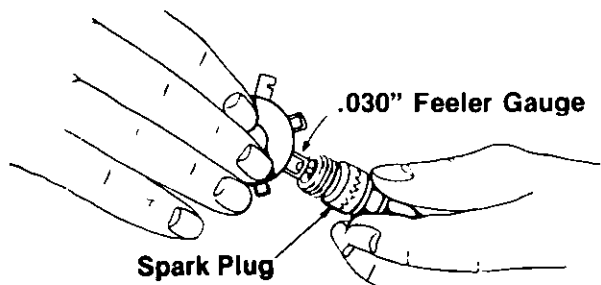

FIGURE 38.

# STORAGE

If the tiller is not to be used for a while, the following procedure should be followed. The tines, depth bar, transmission and wheels should be cleaned of all dirt. It is very important that the unit be stored in a level position to prevent engine oil from draining into the cylinder head cavity.

Engines on tillers to be stored between seasons should be completely drained of fuel to prevent gum deposits forming on essential carburetor parts, and fuel tank.

## TILLER INSTRUCTIONS FOR WINTER OPERATION (under 40°F.)

**Engine Lubrication.** Drain the summer engine oil while engine is warm. Refill with new "winter grade" oil. Run engine until warm to distribute the new winter oil.

Use oil "for service" SC, SD, or SE. Use 5W-20 or 5W-30. If not available, use 10W, or 10W-30.

**Fuel.** Replace any summer gasoline on hand or in the fuel tank with fresh winter-grade gasoline. Use lead-free or leaded "regular" grade automotive gasoline. Winter fuels have additives for faster starting. Keep fuel tank full.

**NOTE**

Many automotive gasolines no longer contain "de-icer." A can of gasoline de-icer fluid added to your gasoline supply will help maintain the engine's winter reliability.

### Cold Starting Hints

1. Be sure to use proper winter-grade oil and gasoline.
2. Declutch all possible external loads.
3. Set governor control at low-speed position.
4. Turn carburetor needle valve approximately 1/8 turn counterclockwise. (Richer fuel mixture) This will improve cold weather starting and operation.

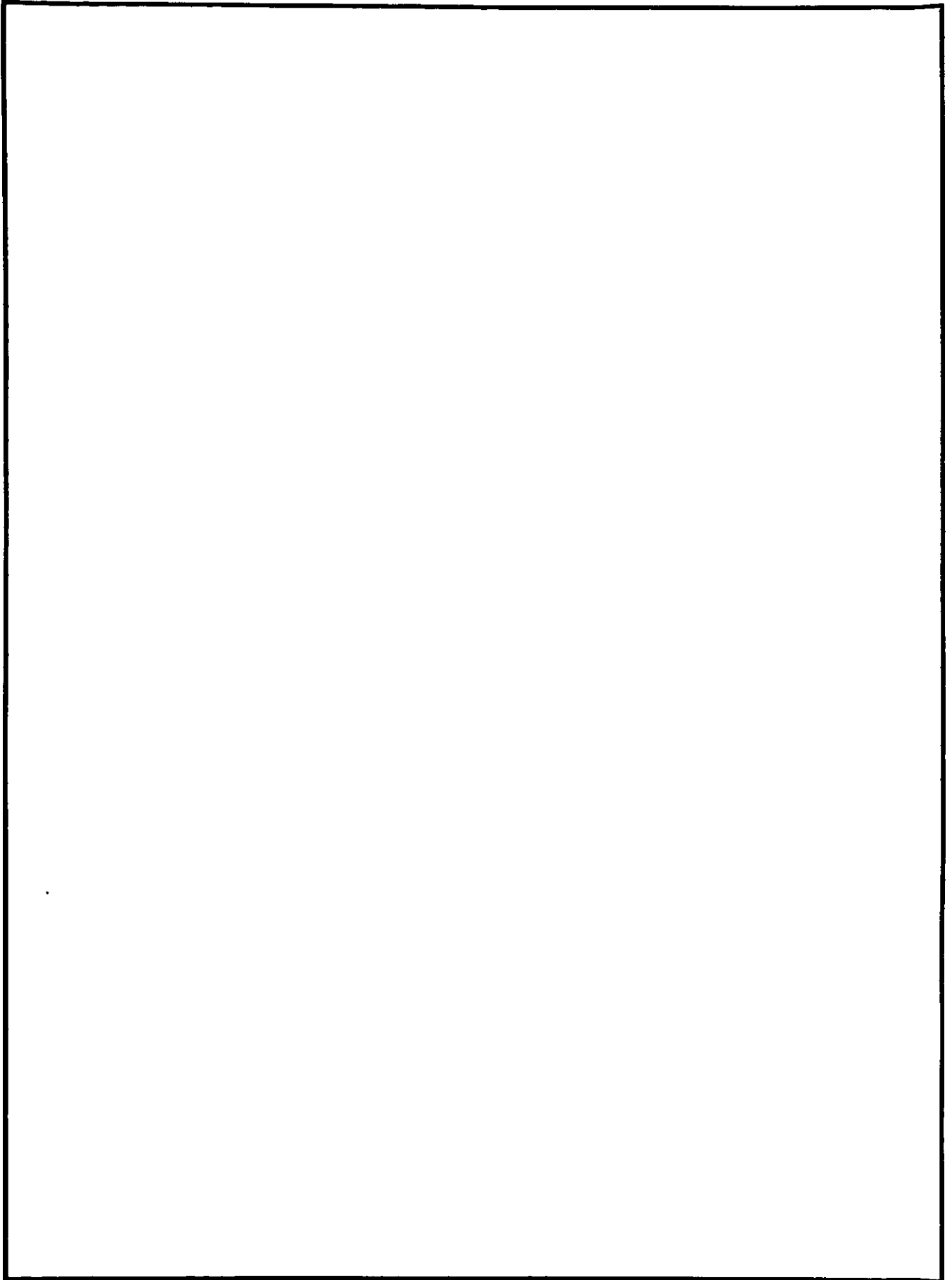

# NOTES

A large, empty rectangular box with a black border, intended for writing notes. It occupies most of the page below the title and above the footer.

# Repair Parts 8-H.P. Tiller Model 247.298760

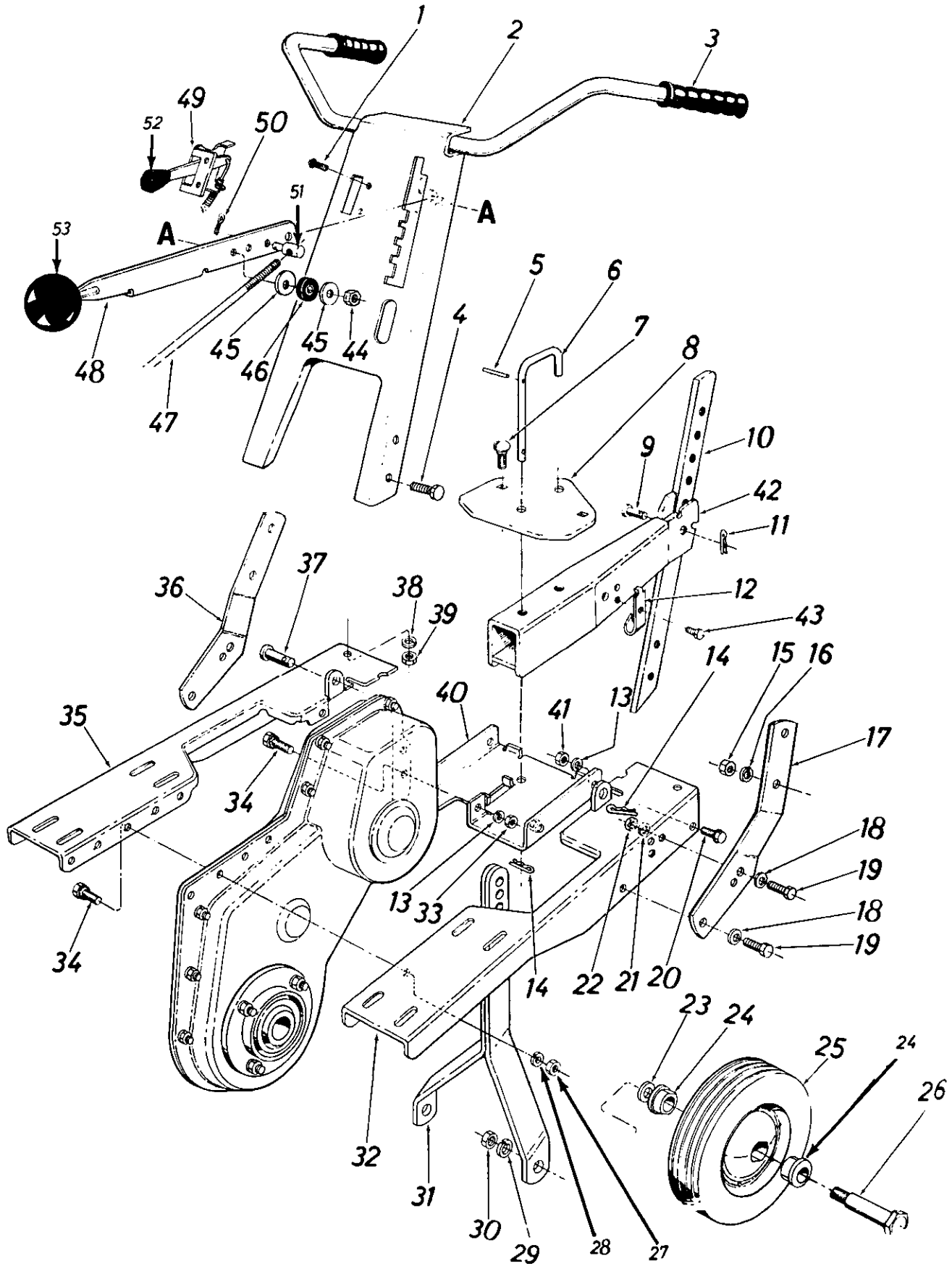

# Repair Parts 8-H.P. Tiller Model 247.298760

REF. NO.	PART NO.	DESCRIPTION	REF. NO.	PART NO.	DESCRIPTION
1	710-0160	Hex Wash. Hd. AB-Tapp Scr. #8 x .62" Lg.*	28	736-0119	L-Wash. 5/16" Scr.*
2	04777	Handle Ass'y.	29	736-0921	L-Wash. 1/2" Scr.*
3	01166	Grip	30	712-0239	Hex Cent. L-Nut 1/2-20 Thd.
4	710-0253	Hex Scr. 3/8-16 x 1.00" Lg.*	31	06813	Wheel Yoke Ass'y.
5	715-0119	Spring Roll Pin 5/32" Dia. x 1.12" Lg.	32	06792	Engine "U"-Channel Ass'y.—L.H.
6	04602	"U"-Clevis Pin .500" Dia.	33	712-0267	Hex Nut 5/16-18 Thd.*
7	710-0451	Carr. Bolt 5/16-18 x .75" Lg.*	34	710-0322	Hex Sems Scr. 5/16-18 x 1.00" Lg.
8	04586	"U"-Channel Plate	35	06794	Engine "U"-Channel Ass'y.—R.H.
9	711-0599	Clevis Pin	36	06806	Handle Brkt.—R.H.
10	06811	Depth Bar	37	711-0599	Clevis Pin
11	714-0145	Internal Cotter Pin	38	736-0119	L-Wash. 5/16" Scr.*
12	732-0322	Depth Bar Spring Clip	39	712-0267	Hex Nut 5/16-18 Thd.*
13	736-0119	L-Wash. 5/16" Scr.*	40	06816	"U"-Channel Brkt. Ass'y.
14	714-0145	Internal Cotter Pin	41	712-0267	Hex Nut 5/16-18 Thd.*
15	712-0798	Hex Nut 3/8-16 Thd.*	42	06807	Tail Piece
16	736-0169	L-Wash. 3/8" Scr.*	43	710-0599	Thread Rolling Scr. 1/4-20 x .50" Lg.
17	06805	Handle Brkt.—L.H.	44	712-0158	Hex Cent. L-Nut 5/16-18 Thd.
18	736-0105	Bell. Wash. 3/8" I.D.	45	736-0159	Fl-Wash. .344 I.D. x .87" O.D.
19	710-0152	Hex Scr. 3/8-24 x 1.00" Lg.*	46	735-0126	Rubber Wash.
20	710-0118	Hex Sems Scr. 5/16-18 x .75" Lg.*	47	747-0271	Control Rod
21	736-0169	L-Wash. 3/8" Scr.*	48	04810	Shift Lever
22	712-0241	Hex Nut 3/8-24 Thd.*	49	746-0272	Throttle Control Ass'y. Comp.
23	736-0253	Bell. Wash.	50	714-0145	Internal Cotter Pin
24	741-0116	Flange Brg. w/Flats .631 I.D.	51	711-0198	Ferrule
25	734-0584	Wheel Ass'y. Comp.	52	731-0189	Knob—Throttle Control
26	738-0318	Shld. Bolt .625" Dia. x 2.75" Lg. 1/2-20 Thd.	53	720-0183	Ball Knob—Shift Lever
27	712-0267	Hex Nut 5/16-18 Thd.*			

\*Standard Hardware Items—May Be Purchased Locally.

# Repair Parts 8-H.P. Tiller Model 247.298760

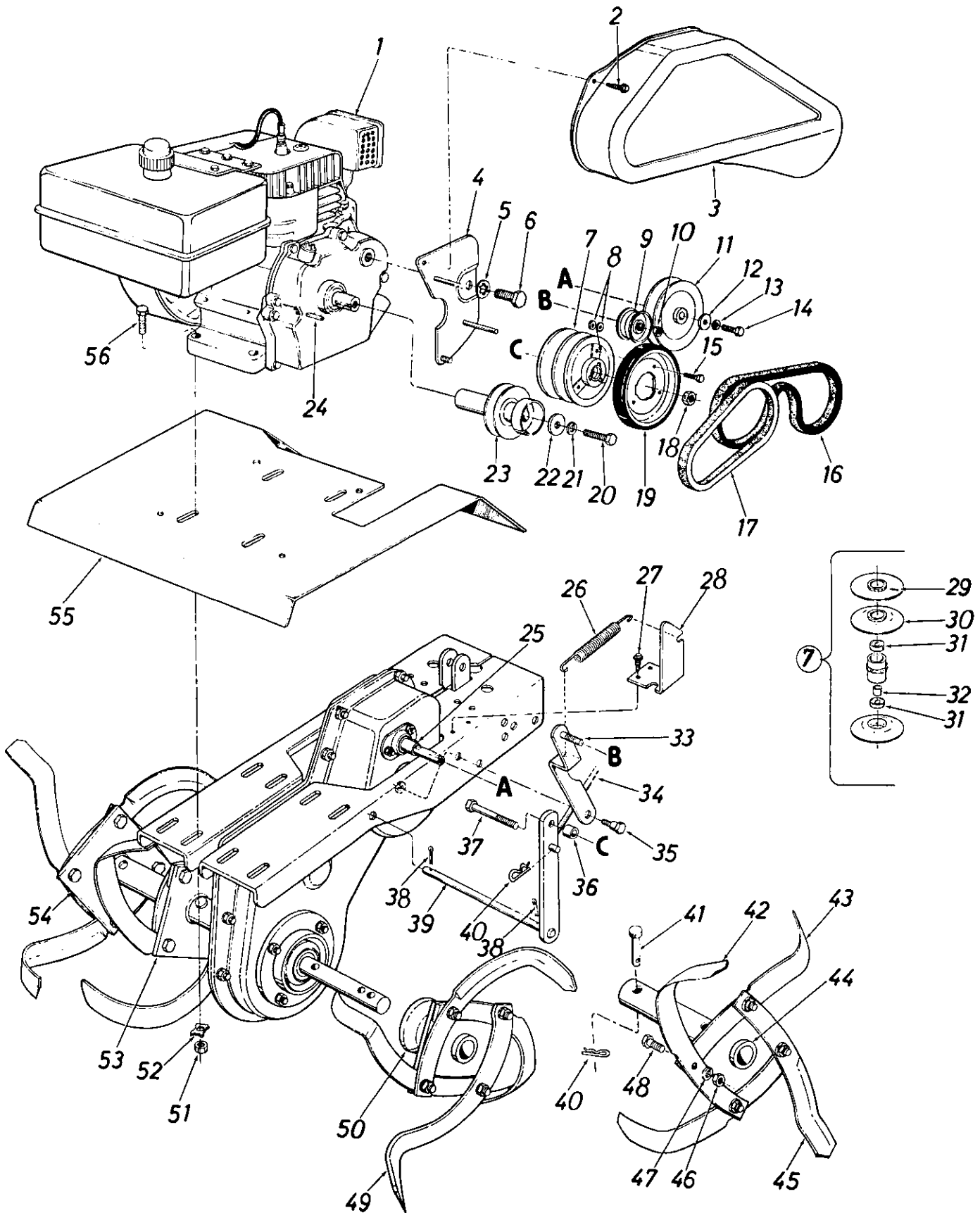

# Repair Parts 8-H.P. Tiller Model 247.298760

REF. NO.	PART NO.	DESCRIPTION	REF. NO.	PART NO.	DESCRIPTION
1	752-0663	Engine Tecumseh Model HM80-15162E	28	04898	Belt Guard Support—Rear
2	710-0599	Thread Rolling Scr. 1/4-20 x .50" Lg.	29	715-0124	Spring Pin Spiral 5/32 Dia. x .62" Lg.
3	04899	Belt Cover	30	10844	Sheave Half
4	04896	Front Belt Guard Support Ass'y.	31	741-0139	Ball Bearing
5	736-0114	Internal L-Wash. 1/2" Dia.	32	750-0146	Spacer
6	710-0121	Hex Scr. 1/2-20 x .15 Special	33	04893	Idler Arm Ass'y.
7	717-0390	Variable Speed Pulley Ass'y.	34	747-0271	Control Rod 3/8" Rod
8	736-0142	FI-Wash. .281 I.D. x .50 O.D. x .63	35	738-0140	Shld. Bolt .437 Dia. x .180
9	756-0313	Idler Pulley	36	711-0494	Spacer .510 I.D. x .760 O.D. x .390" Lg.
10	712-0262	Hex Jam Nut 3/8-24 Thd.	37	710-0515	Hex Scr. 1/2-20 x 3.50" Lg.
11	756-0305	Pulley 4.50" Dia.	38	714-0115	Cotter Pin 1/8" Dia.*
12	736-0231	FI-Wash. 5/16" I.D. x 1.120" O.D.	39	04889	Pivot Arm Ass'y.
13	736-0119	L-Wash. 5/16" Scr.*	40	714-0145	Internal Cotter Pin 1/2" Dia.
14	710-0573	Hex Scr. 5/16-18 x 1.25" Lg.*	41	711-0599	Clevis Pin
15	710-0230	Hex Scr. 1/4-28 x .50" Lg.*	42	742-0175	Tine—L.H.
16	754-0231	"V"-Belt 1/2" x 28" Lg.	43	742-0174	Tine—R.H.
17	754-0232	"V"-Belt 1/2" x 20" Lg.	44	06797	Outer Tine Adapter Ass'y.
18	712-0239	L-Nut 1/2-20 Thd.	45	04695	Outer Tine Ass'y. Comp.—L.H.
19	04900	Friction Wheel Ass'y.	46	712-0241	Hex Nut 3/8-24 Thd.*
20	710-0191	Hex Scr. 3/8-24 x 1.25" Lg.*	47	736-0169	L-Wash. 3/8" Scr.*
21	736-0169	L-Wash. 3/8" Scr.*	48	710-0191	Hex Scr. 3/8-24 x 1.25" Lg.*
22	736-0258	FI-Wash. 3/8" I.D. x 1.00" O.D.	49	06821	Inner Tine Ass'y. Comp.—L.H.
23	756-0306	Engine Pulley	50	06798	Inner Tine Adapter Ass'y.
24	714-0133	Sq. Key 3/16 x 1.50" Lg.	51	712-0267	Hex Nut 5/16-18 Thd.*
25	750-0229	Spacer .635" I.D. x .88 O.D. x 1.035" Lg.	52	736-0170	Shakeproof Washer
26	732-0376	Extension Spring	53	06822	Inner Tine Ass'y. Comp.—R.H.
27	710-0599	Hex Tapp Scr. 1/4-20 x .50" Lg.	54	04696	Outer Tine Ass'y. Comp.—R.H.
			55	04776	Tine Shield
			56	710-0442	Hex Scr. 5/16-18 x 1.50" Lg.*

\*Standard Hardware Items—May Be Purchased Locally.

## TILLER ACCESSORIES

Til-Row Attachment	8" Furrower
Leveling/Snow-Blade Kit	15" Sweep Cult./Hoe
V-Bar Cultivating Kit	32" Leveling Rake
Drag Stake Cultivating Kit	Cultivating Shields
V-Bar Frame	32" Leveling/Snow-Blade
4-pt. Cultivator Tines	13 x 5.00—6 Pneumatic Traction Tires
Hiller/Furrower	Wheel Weights
Depth Gauge Wheels	Tire Chains (Pr.)
6-Tang Universal Cult.	Wheel Weights F/Leveling Snow-Blade
Drag Stake	

THESE ACCESSORIES ARE AVAILABLE IN THE SEARS BIG SPRING CATALOG.

# Repair Parts 8-H.P. Tiller Model 247.298760

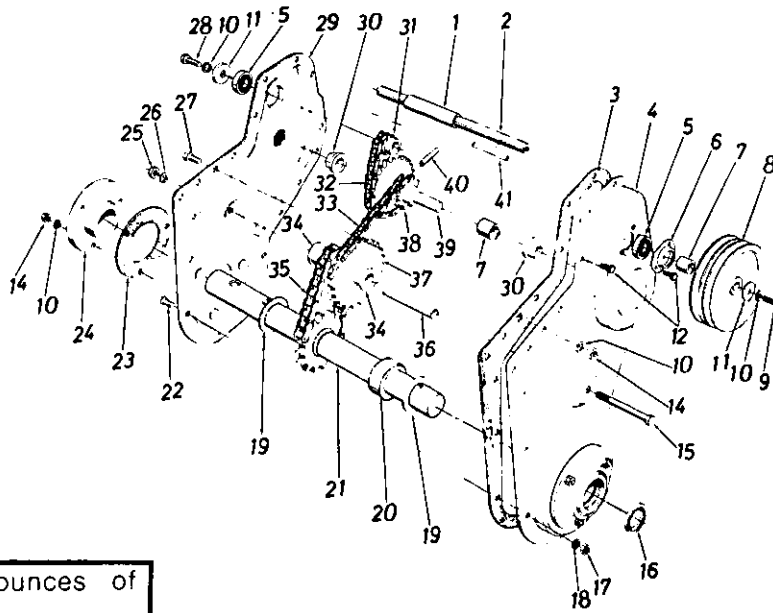

NOTE: Use 14 ounces of  
Plastilube #1  
Order Part No. 737-0133

## Repair Parts Transmission 04907

REF. NO.	PART NO.	COLOR CODE	DESCRIPTION	NEW PART	REF. NO.	PART NO.	COLOR CODE	DESCRIPTION	NEW PART
1	750-0315		Spacer .657 I.D. x .78 O.D. x 2.19	N	21	06800		Tine Shaft Ass'y.	N
2	738-0182		Jack Shaft		22	710-0195		Hex Scr. 1/4-28 x .62" Lg.*	
3	721-0132		Gasket for Housing		23	721-0133		Gasket for Bearing Hsg.	
4	04885		Housing Half—L.H.		24	741-0198		Bearing Housing Ass'y.	
5	741-0155		Ball Bearing .625 I.D. x 1.375 O.D.		25	712-0798		Hex Nut 3/8-16 Thd.*	
6	05034		Bearing Housing		26	736-0169		L-Wash. 3/8" Scr.*	
7	750-0229		Spacer .625 I.D. x .88 O.D. x 1.035		27	710-0322		Hex Sems Scr. 5/16-18 x 1.00" Lg.*	
8	756-0264		Chain Case Pulley 6.00" Dia. (380)		28	710-0538		Hex Scr. 5/16-18 x .62" Lg. Special	
	756-0262		Chain Case Pulley 6.00" Dia. (385)		29	04886		Housing Half—R.H.	
9	710-0643		Hex Scr. 5/16-18 x 1.00" Lg. Special		30	748-0229		Hex Flanged Bearing .630 I.D.	
10	736-0119		L-Wash. 5/16" Scr.*		31	713-0206		Sprocket 10 Teeth x .500 Pitch	
11	736-0231		Fl-Wash. 5/16 I.D. x 1.125 O.D. x .125		32	713-0131		#41 Chain 1/2" Pitch x 33 Links Endless	
12	710-0599		Hex Wash. Hd. Self Tapp. Scr. 1/4-20 x .50" Lg.		33	713-0186		#42 Chain 1/2" Pitch x 48 Links Endless	
14	712-0267		Hex Nut 5/16-18 Thd.*		34	748-0855		Flange Bearing .628 I.D.	
15	710-0644		Hex Scr. 3/8-16 x 3.25" Lg.		35	713-0187		#50 Chain 5/8" Pitch x 28 Links Endless	
16	721-0102		Oil Seal 1" I.D. x 1.357 O.D.		36	738-0320		Sprocket Shaft	
17	712-0138		Hex Nut 1/4-28 Thd.*		37	713-0182		Sprocket Bearing Sleeve Ass'y.	
18	736-0329		L-Wash. 1/4" Scr.*		38	713-0181		Sprocket Sleeve Ass'y.	
19	736-0259		Fl-Wash. 1.0" I.D. x 1.62 O.D. x .090		39	738-0308		Sprocket Shaft	
20	750-0314		Spacer 1.0" I.D. x 2.0" O.D. x .68		40	715-0114		Spring Pin Spiral 1/4" Dia. x 1.5" Lg.	
				41	714-0133		Sq. Key 3/16 x 1.50" Lg.		

\*For faster service obtain standard nuts, bolts, and washers locally. If these items cannot be obtained locally, order by part number and size as shown on parts list.

# TECUMSEH 4-CYCLE ENGINE

MODEL NUMBER: HM80-155162E

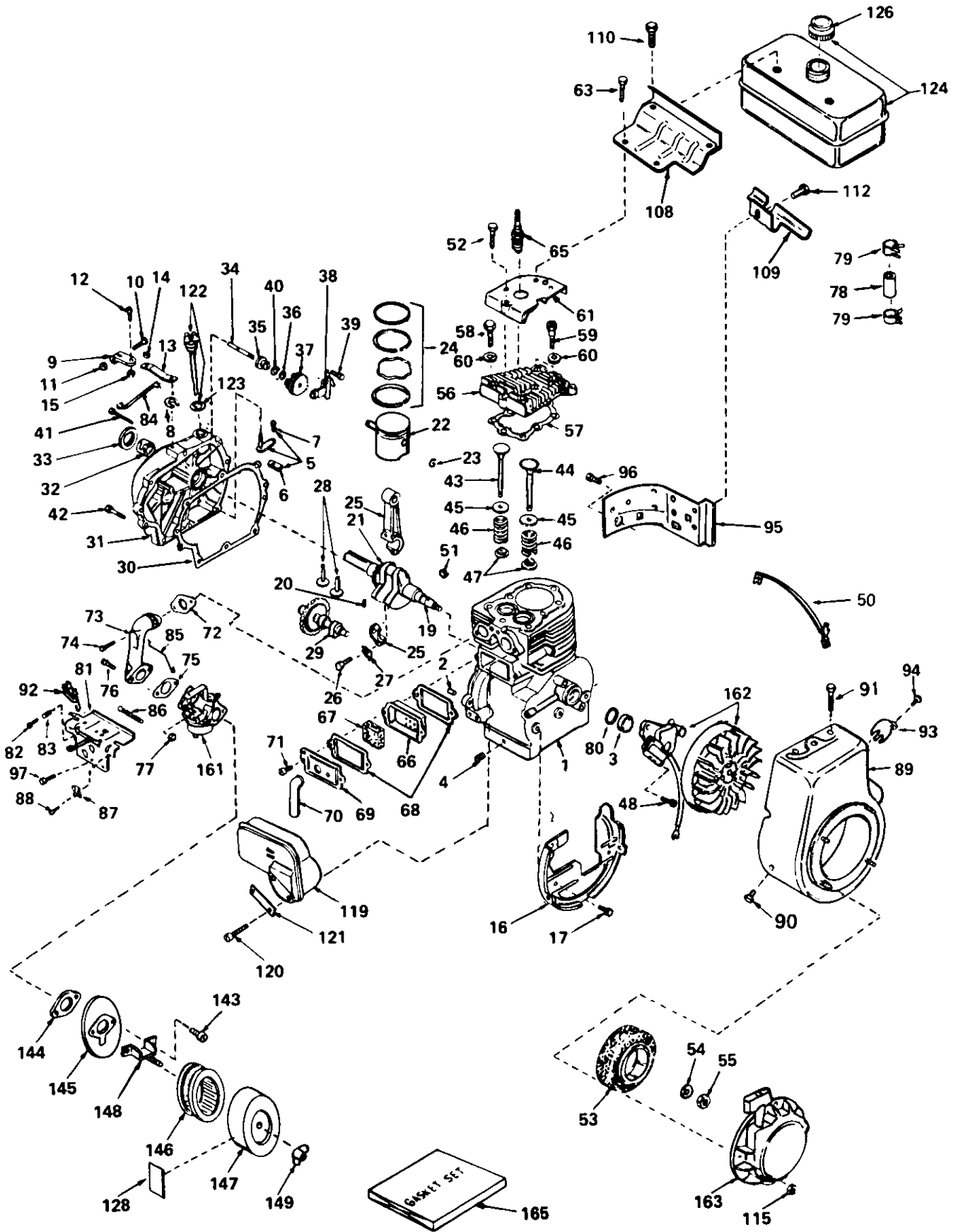

# TECUMSEH 4-CYCLE ENGINE

MODEL NUMBER: HM80-155162E

Ref. No.	Part No.	Part Name	Ref. No.	Part No.	Part Name
1	34348	Cylinder Assy. (Incl. Nos. 2, 3 & 4)	57	*34031	Gasket, Cylinder head
2	27652	Pin, Dowel	58	6021A	Screw, Hex hd. cap, 5/16-18 x 1-1/2
3	32630	Seal, Oil	59	650727	Screw, Special hex hd. tapped, 5/16-18 x 1-3/4
4	27642	Plug, Oil drain	60	650691	Washer, Flat
5	30699C	Rod Assy., Governor (Incl. Nos. 6 & 7)	61	33272	Cover, Cylinder head
6	30700	Yoke, Governor	63	650713	Screw, Hex hd., 5/16-18 x 5/8
7	650494	Screw, Fil. hd. Sems, 6-40 x 5/16	65	33636	Plug, Spark (Champion J-8 or equivalent) <u>Except for Canada</u>
8	29642	Ring, Retaining	65	34251	Resistor Spark Plug (Canadian Regulations require RJ-17LM resistor spark plug)
9	29916	Clamp, Governor lever	66	28423	Body, Breather
10	29826	Screw, Hex washer hd., 10-32 x 3/4	67	28424	Element, Breather
11	29216	Nut, Square, 10-32	68	*27896	Gasket, Breather cover
12	650548	Screw, Hex washer hd., 8-32 x 5/16	69	28425	Cover, Valve spring
13	33364	Lever, Governor	70	27627	Tube, Breather
14	29918	Lockwasher, No. 8 E.T.	71	650128	Screw, Fil. slotted hd. Sems, 10-24 x 1/2
15	30322	Nut & Lockwasher., 8-32	72	*27915	Gasket, Intake pipe
16	29536	Baffle, Blower housing	73	33877	Pipe, Intake
17	650561	Screw, Hex hd. Sems, 1/4-20 x 5/8	74	650378	Screw, Fil. hd. Sems, 5/16-18 x 1-1/8
19	33365B	Crankshaft Assy. (Incl. Nos. 20 & 21)	75	*33861	Gasket, Carburetor
20	29783	Pin, Crankshaft gear	76	30088A	Screw, Fil. hd. Sems, 1/4-28 x 1
21	33245	Gear, Crankshaft	77	29752	Nut & Lockwasher, 1/4-28
22	34329	Piston, Pin & Ring Assy. (Std.) (Incl. Nos. 23 & 24)	78	30705	Line, Fuel
22	34330	Piston, Pin & Ring Assy. (.010 oversize) (Incl. Nos. 23 & 24)	79	26460	Clamp, Fuel line
22	34331	Piston, Pin & Ring Assy. (.020 oversize) (Incl. Nos. 23 & 24)	80	33876	Gasket, Stator
23	27888	Ring, Piston pin retaining	81	33461A	Control Assy., Speed (Incl. Nos. 82, 83, 86 & 92)
24	34332	Ring Set, Piston (Std.)	82	650549	Screw, Fil. hd., 5-40 x 7/16
24	34333	Ring Set, Piston (.010 oversize)	83	31342	Spring, Compression
24	34334	Ring Set, Piston (.020 oversize)	84	33371	Link, Governor lever-to-bellcrank
25	32591C	Rod Assy., Connecting (Incl. Nos. 26 & 27)	85	33878	Link, Governor lever-to-throttle
26	650662A	Bolt, Connecting rod	86	33374	Spring, Extension
27	34242	Dipper, Oil	87	27793	Clip, Conduit
28	34034	Lifter, Valve	88	28942	Screw, Hex hd. Sems, 10-32 x 3/8
29	34143	Camshaft (Mech. Compression Release)	89	33375B	Housing, Blower
30	*33253	Gasket, Cylinder cover	90	29747A	Screw, Hex hd. Sems, 5/16-24 x 3/4
31	33367A	Cover, Cylinder (Incl. Nos. 32, 33 & 34)	91	650788	Screw, Hex hd. spin-lock thread forming, 5/16-18 x 3/4
32	33368	Bushing, Crankshaft	92	610973	Terminal Assy.
33	31950	Seal, Oil	93	33013	Cover, Starter bubble
34	31845	Shaft, Mechanical governor	94	650760	Screw, Pan hd., taptite, 8-32 x 7/16
35	30588A	Spool, Governor	95	33273	Extension, Blower housing
36	29193	Ring, Retaining	96	650128	Screw, Fil. slotted hd. Sems, 10-24 x 1/2
37	30591	Gear Assy., Governor (Incl. No. 40)	97	29919	Screw, Hex washer hd. Sems, taptite, 8-32 x 1/2
38	33369	Bracket, Governor gear	108	34154	Plate, Fuel tank mounting
39	28763	Screw, Hex washer hd. shakeproof, 10-32 x 19/32	109	34155	Bracket, Tank mounting
40	30590A	Washer, Flat	110	650665	Screw, Hex washer hd. Sems, self-tap, 1/4-14 x 7/8
41	650488	Screw, Hex hd. Sems, 1/4-20 x 1-1/4	112	650561	Screw, Hex hd. Sems, 1/4-20 x 5/8
42	650493	Screw, Hex hd. Sems, 1/4-20 x 1-3/4	115	29752	Nut & Lockwasher, 1/4-28
43	34035	Valve, Intake (Std.) (Incl. No. 47)	119	33756	Muffler
43	34036	Valve, Intake (1/32" oversize) (Incl. No. 47)	120	650729	Screw, Hex hd., 5/16-18 x 3-3/16
44	27878A	Valve, Exhaust (Std.) (Incl. No. 47)	121	31598	Plate, Muffler locking
44	27880A	Valve, Exhaust (1/32" oversize) (Incl. No. 47)	122	31297	Dipstick, Oil (Incl. No. 123)
45	27882	Cap, Upper valve spring	123	*29673	Gasket, Dipstick
46	27881	Spring, Valve	124	34156	Tank Assy., Fuel (Incl. No. 126)
47	32581	Cap, Lower valve spring	126	32387A	Cap, Fuel filler
48	650489	Screw, Hex hd. Sems, 1/4-20 x 5/8	128	34374	Decal, Instruction
50	34235	Wire, Ground	143	28820	Screw, Fil. hd. Sems, 10-32 x 1/2
51	32589	Key, Flywheel	144	*27272	Gasket, Air cleaner
52	650737	Screw, Hex washer hd. taptite, 1/4-20 x 1/2	145	33266	Bracket, Air cleaner
53	33662	Hub & Screen Assy., Starter	146	33268	Element, Air cleaner
54	650490	Washer, Belleville	147	33269A	Cover, Air cleaner
55	8116	Nut, Hex			
56	34030	Head, Cylinder			

\* Indicates Parts Included in Gasket Set, Ref. No. 165.



# TECUMSEH 4-CYCLE ENGINE

MODEL NUMBER: HM80-155162E

Ref. No.	Part No.	Part Name	Ref. No.	Part No.	Part Name
148	33267	Bracket, Air cleaner	163	590479	Starter, Rewind
149	650513	Nut, Wing, 1/4-20	165	33279C	Gasket Set (Incl. items marked *)
161	631979	Carburetor (Incl. No. 75)		694138	Owners Manual
162	610842	Magneto (The complete magneto is not available as an assembly. The magneto number is shown for reference purposes only. Order component parts individually, as shown in parts list.)			*Indicates Parts Included in Gasket Set, Ref. No. 165.

## CARBURETOR NO. 631979

Ref. No.	Part No.	Part Name
1	631979	Carburetor
2	631776	Shaft & Lever Assy., Throttle
3	631970	Spring, Throttle return
4	631778	Shutter, Throttle
5	650506	Screw, Rd. hd., 4-40 x 3/16
5A	630766	Spring, Idle regulating screw
6	630738	Spring, Main adjustment screw
7	650417	Screw, Idle regulating
8	631812	Shaft & Lever Assy., Choke
9	630735	Spring, Choke return
10	631753	Shutter, Choke
11	*630748	Plug, Welch
12	*631027	Plug, Welch
13	*631021	Inlet Needle, Seat & Clip Assy. (Incl. No. 13)
14	631022	Clip, Inlet needle
15	632019	Float, Carburetor
16	*631024	Shaft, Float
17	631867	Bowl, Float
18	632043	Spring
21	631183	Washer, Felt
22	27110	Gasket, Bowl-to-body
23	*631583	Adjustment Screw Assy., Main (Incl. Nos. 5A, 21, 23 & 30)
24	630740	"O" Ring, Adjustment screw
25	*630898	Screw, Idle adjustment
26	*631028	Gasket, Bowl-to-body
27	631803	Fuel Fitting
28	631184	Washer
29	631972	Retainer, Seal
30	631971	Seal, Dust
31	630739	Washer, Flat
	631978	Repair Kit (Incl. items marked *)

**MAGNETO NO. 610842**

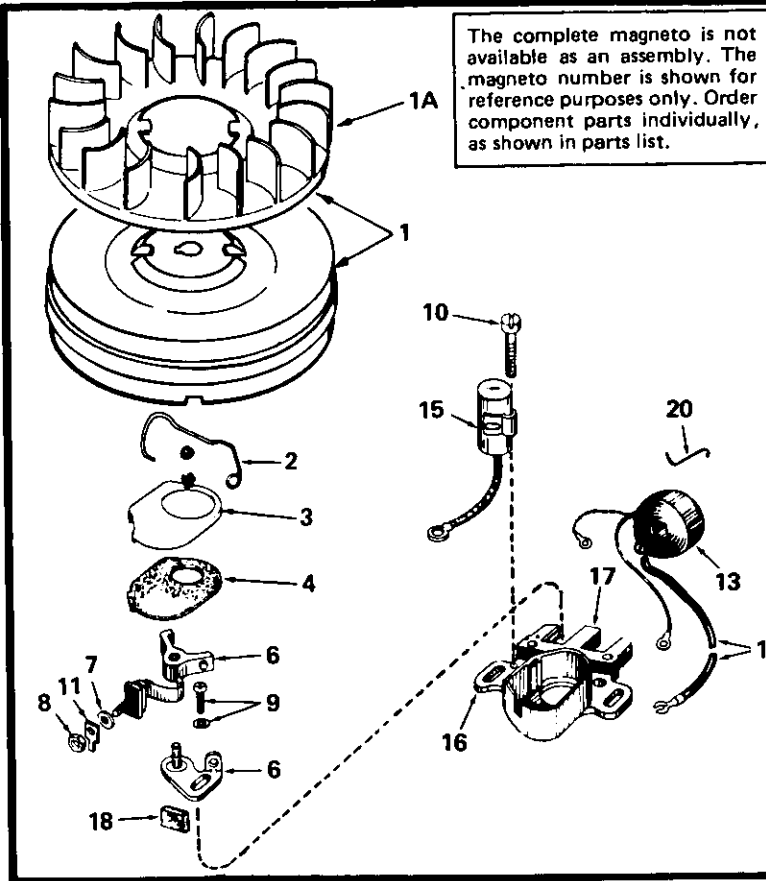

Ref. No.	Part No.	Part Name
1	610842	Magneto
1A	610841	Flywheel (Incl. No. 1A)
2	610934	Fan
3	30551	Spring, Breaker box dust cover
4	610947	Cover, Dust
6	610957	Gasket, Dust cover
7	30547A	Breaker Assembly
8	610385	Washer, Terminal
9	610408	Nut, Terminal
10	29181	Screw and Washer Assembly, Breaker
11	610593	Screw, Condenser fastening
13	33356	Tab, Ground terminal
14	30560A	Coil Assembly (Incl. No. 14)
15	30554	Wire, Ignition lead
16	30548A	Condenser
17	30545	Core and Plate Group
18	30561B	Stator Assembly (Incl. Nos. 2, 3, 4, 6 thru 16, 18 & 20)
18	30549	Felt, Cam wiper
20	31311	Clip, Coil locking

**REWIND STARTER NO. 590479**

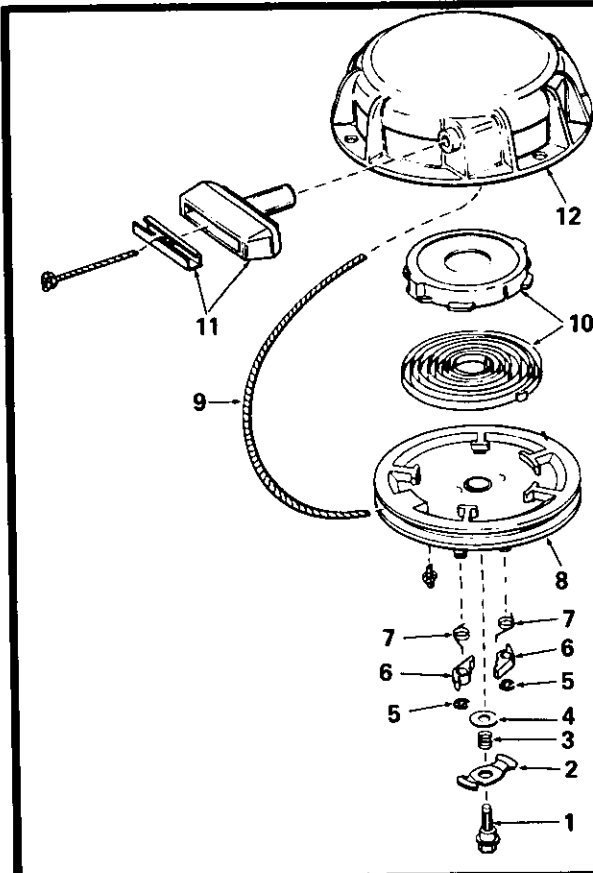

Ref. No.	Part No.	Part Name
	590479	Rewind Starter
1	590480	Screw, Center
2	590481	Cam, Dog
3	590482	Spring, Brake
4	32024	Washer, Brake
5	590483	Ring, Retainer
6	590484	Dog
7	590485	Spring, Dog
8	590486	Pulley & Bearing Assy.
9	590456	Rope, Starter
10	590487	Spring & Keeper Assy.
11	590387	Handle Assy., Starter
12	590488	Housing Assy., Starter



1



**Sears**

**owners  
manual**

**MODEL NO.  
247.298760**

**Sears  
SERVICE  
is at  
Your  
SERVICE**

## HOW TO ORDER REPAIR PARTS

The Model Number will be found stamped on a plate attached to the chassis. Always mention the Model Number when requesting service or repair parts for your tiller.

All parts listed herein may be ordered through SEARS ROEBUCK AND CO. or SIMPSON SEARS LIMITED RETAIL or CATALOG STORE.

WHEN ORDERING REPAIR PARTS, ALWAYS GIVE THE FOLLOWING INFORMATION AS SHOWN IN THIS LIST.

1. The PART NUMBER
2. The MODEL NUMBER 247.298760
3. The PART DESCRIPTION
4. The NAME OF MERCHANDISE— Tiller

If the parts you need are not stocked locally, your order will be electronically transmitted to a Sears Repair Parts Distribution Center for expedited handling.

Your Sears merchandise takes on added value when you discover that Sears has over 2,000 Service Units throughout the country. Each is staffed by Sears-trained, professional technicians.

**SEARS, ROEBUCK AND CO., Chicago, Ill. 60684 U.S.A.**